

LACONIA FIRE DEPARTMENT

Motorcycle Week Propane Tank Permitting

Permits are required for all temporary tanks, except as noted below.

Temporary permits shall be valid for the period specified on the permit.

Permits may be obtained at the Laconia Central Fire Station, 848 North Main Street between 9:00 am and 3:00 pm.

A \$10.00 fee per tank is required.

Minimum size temporary tank is 50 gallons (200 LBS.)

Maximum size tank is 100 gallons (420 LBS.)

The following exceptions apply: (No permit is required)

Tanks permanently attached to food service trailers, 2 40-lbs cylinders maximum.

20 lbs cylinders supplying residential gas grills or portable food carts, 2 cylinders maximum per site.

Tanks shall be on a firm surface and shall not be located along or under any walkway or customer service area.

Tanks shall be attached to appliances via a rubber hose assembly. Larger venues may use back iron pipe where necessary.

All installations are subject to inspection and approval of the Laconia Fire Department.

No tanks shall be filled during normal operating hours or at times of increased public activity.

Tanks shall be removed within 24 hours of the conclusion of the event.

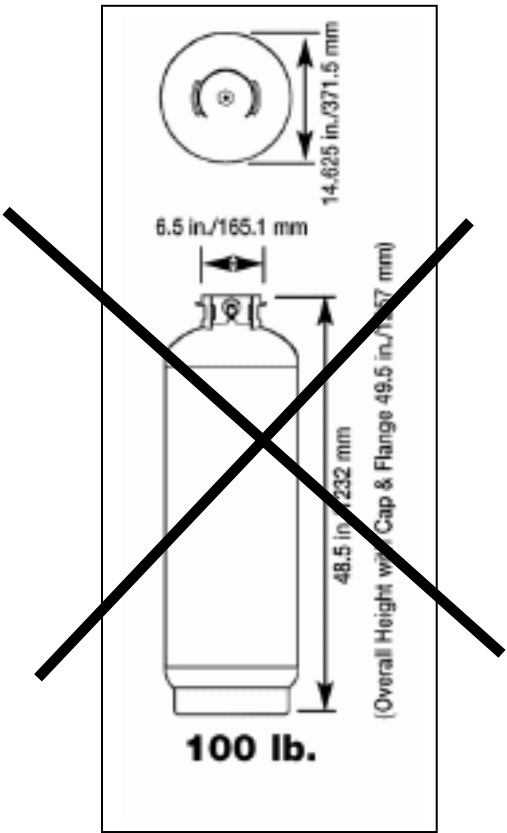

PROHIBITED

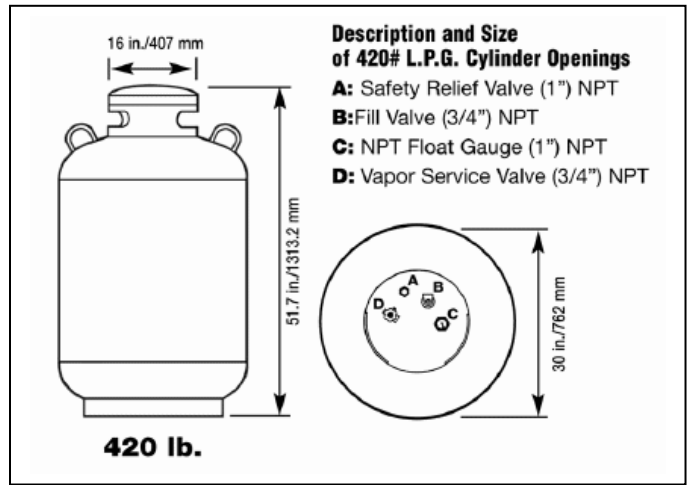

Description and Size of 420# L.P.G. Cylinder Openings

- A:** Safety Relief Valve (1") NPT
- B:** Fill Valve (3/4") NPT
- C:** NPT Float Gauge (1") NPT
- D:** Vapor Service Valve (3/4") NPT

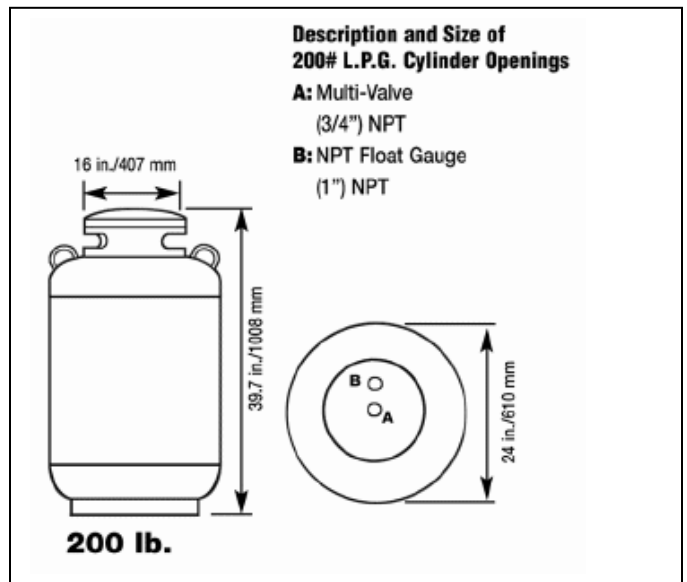

Description and Size of 200# L.P.G. Cylinder Openings

- A:** Multi-Valve (3/4") NPT
- B:** NPT Float Gauge (1") NPT

APPROVED